

## NOTICIAS

Art. 876/12  
Art. 876/16  
Art. 876/18  
Art. 876/20  
Art. 876/22  
Art. 876/24



Bisagra  
PRATICO®

Art. 920.12  
Art. 920.16  
Art. 920.18  
Art. 920.20  
Art. 920.22  
Art. 920.24



Cojinete  
PRATICO®

Art. 921.12  
Art. 921.16  
Art. 921.18  
Art. 921.20  
Art. 921.22  
Art. 921.24



Placa a soldar  
pour PRATICO®

Art. 922.12  
Art. 922.16  
Art. 922.18  
Art. 922.20  
Art. 922.22  
Art. 922.24



Placa a percutir  
pour PRATICO®

Art. 923.18  
Art. 923.22



Tubo  
PRATICO®

Art. 924.12  
Art. 924.16  
Art. 924.18  
Art. 924.20  
Art. 924.22  
Art. 924.24



Plaque de ouverture  
PRATICO®

Art. 253



Cadena regulable  
con placa anti caída  
para soldar o  
atornillar

Nuestras marcas:



ARTIK

Kassel

NOVAGUIDE

Distribuidor autorizado:

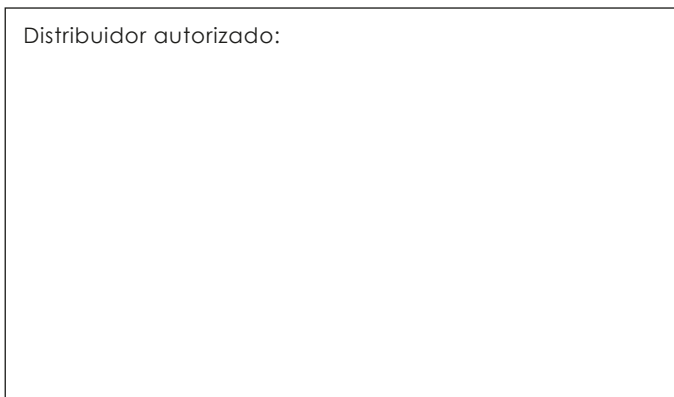

10070 Grosso (TO) - Località Vauda 12  
Tel. 0039 011 92 68 262 - Fax 0039 011 92 60 009  
Mail: info@novaferr.com - www.novaferr.com

Copyright by Nova-Ferr srl - All right reserved

## LÍNEA DE BISAGRA PATENTADAS



# NF Pratico

# 5

5 BUENAS RAZONES  
PARA ELEGIR NUESTRA  
NUEVA BISAGRA

- Resistencia y robustez excepcionales
- Nuevo dispositivo de ajuste
- Rapidez de montaje
- Un diseño innovador
- Totalmente fabricado en Italia

**Composición de la bisagra**

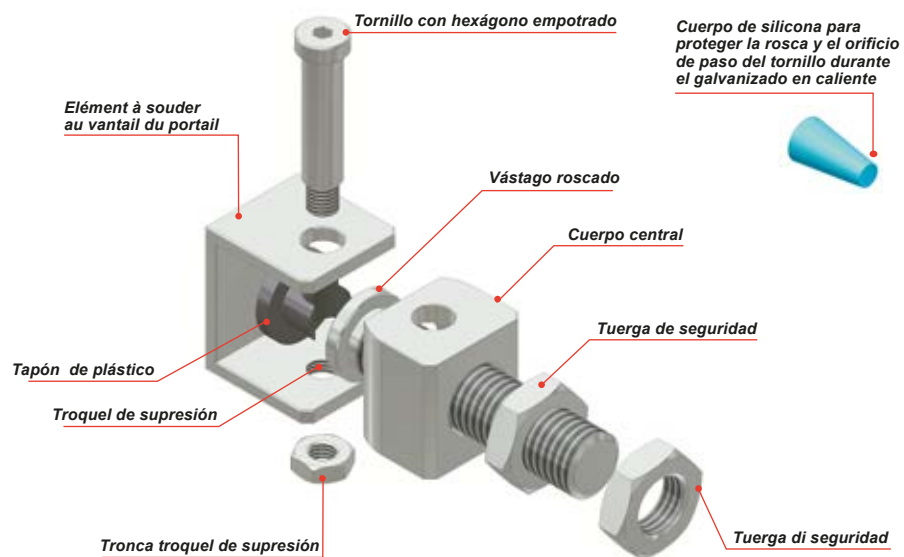

**Ajuste rápido y sencillo PATENTADO**

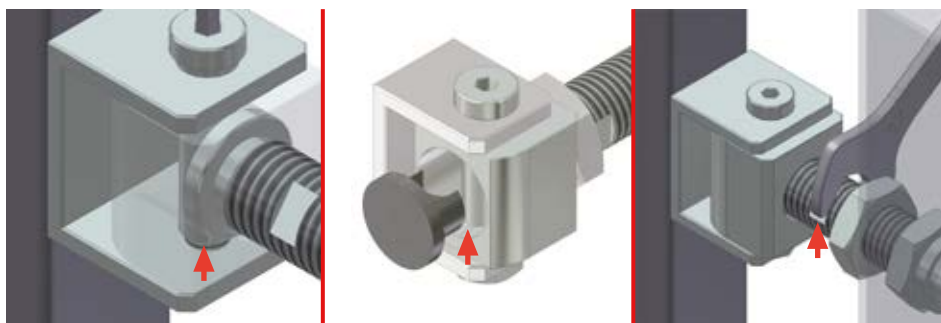

**Ventajas sobre las bisagras tradicionales**

- 1 Durante el montaje, el extremo del pasador entra en contacto con la superficie interior de la lengüeta para garantizar un bloqueo seguro.
- 2 Lugar adecuado para recoger la grasa lubricante
- 3 Una vez aflojada la tuerca hexagonal, gracias al rebaje en el espárrago roscado, el ajuste es mucho más práctico y funcional. el ajuste es fácil en cualquier situación

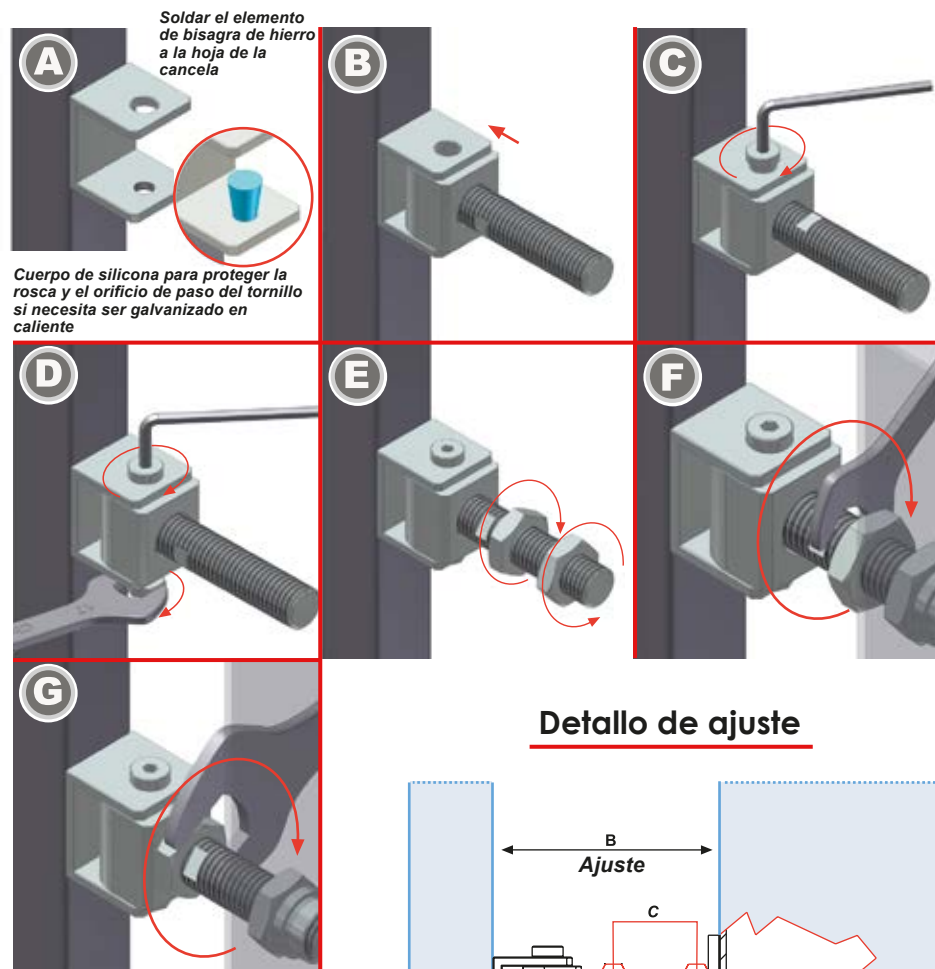

Arf.	B	C	D
M12	65-90	CH19	CH10
M16	75-95	CH24	CH14
M18	79-123	CH27	CH15
M20	79-122	CH30	CH17
M22	85-124	CH32	CH18
M24	88-120	CH36	CH20

